

Take a closer look

FOCUS REFLEX SERVO 250/330
with Re-Register System
ADVANCED TECHNOLOGY PLATFORM



FOCUS
LABEL MACHINERY LTD

Focus Reflex Servo

ADVANCED TECHNOLOGY PLATFORM

Printing in a competitive market today requires high productivity, quality and a cost efficient operation. Focus Label Machinery manufactures a wide range of equipment designed to meet specialised applications.

The introduction of the Reflex Servo coincides with emerging Digital Print technology. Focus has designed an affordable full rotary Servo based system for converting & finishing pre-printed media with the capability of adding additional printed information, protective coatings and die cutting features in a single or multiple pass. The new 'Reflex S' 250mm / 330mm web width lends itself to complement the growing digital formats for short runs.

The Reflex 'S' is also an outstanding performer as a regular press for 'Roll to Roll' or 'Roll to Sheet' converting applications.

INTRODUCTION:

The Re-Register option is easy to manage and operate and is capable of 100m/min plus running speeds.

The bonus of this equipment is that it can be used as a stand alone production tool in its own right for converting blank & single colour Labels, Tags and laser sheets to name a few.

- > New Single Colour Press Design
- > Servo controlled re-register system
- > U.V & IR drying options
- > High speed production
- > Full range of options
- > Compact converting press



TURN BAR
Turn bar units are movable between print stations for greater versatility, with Delam & Re-lamination options for printing on the reverse side of the web or even Multi-Peel labels.



COLD FOIL LAMINATION
The perfect system to add value to a printed web without the cost of specialist tooling. Cold foil technology combines traditional UV flexographic printing technology with special foil lamination for decorative & security applications.



VIDEO INSPECTION
For inspection of the moving web at high speed a number of low cost Video inspection systems are available.



PLC INTERFACE CONTROL
The Operator interface is designed to be intuitive and simple to use, providing finite control & feed back over web tensions, auto register, variable machine speed, adjustable drying systems. In auto register mode the digital drive technology accurately monitors the pre-printed image, utilising it as a reference for any additional processing such as Printing, Cold Foil, Laminating, Varnishing, Die cutting or Sheeting.



WEB GUIDE
The built in Splice table allows trouble free changing of rolls of materials. The Web guide with twin roll guides & edge sensor ensures rolls are delivered through the press accurately. Front mounted controls are easily accessed.



ROTARY / SHEETER DIE STATION
A single Rotary Die Station & dedicated Die/Sheeter Station are standard equipment, with an additional station available as an option. Robust all steel construction ensures perfect converting even on the most difficult of substrates. Front & Back Die cutting facilities are provided, Register adjustment is provided in all directions. Various stacking systems are available for Roll to sheet converting applications.



EXTERNAL UNWIND
With a Built in Web Guide & Splice Table the Unwind Module increases capacity to a massive 1000mm diameter capacity for volume production. Facilities for optional Corona & Web Cleaning systems are provided.



SLITTING
A dedicated Slitting System is standard equipment for edge trimming or slitting individual lanes of labels. The system is easy to set up and adjust. Perforation wheels can also be supplied.

STANDARD REFLEX

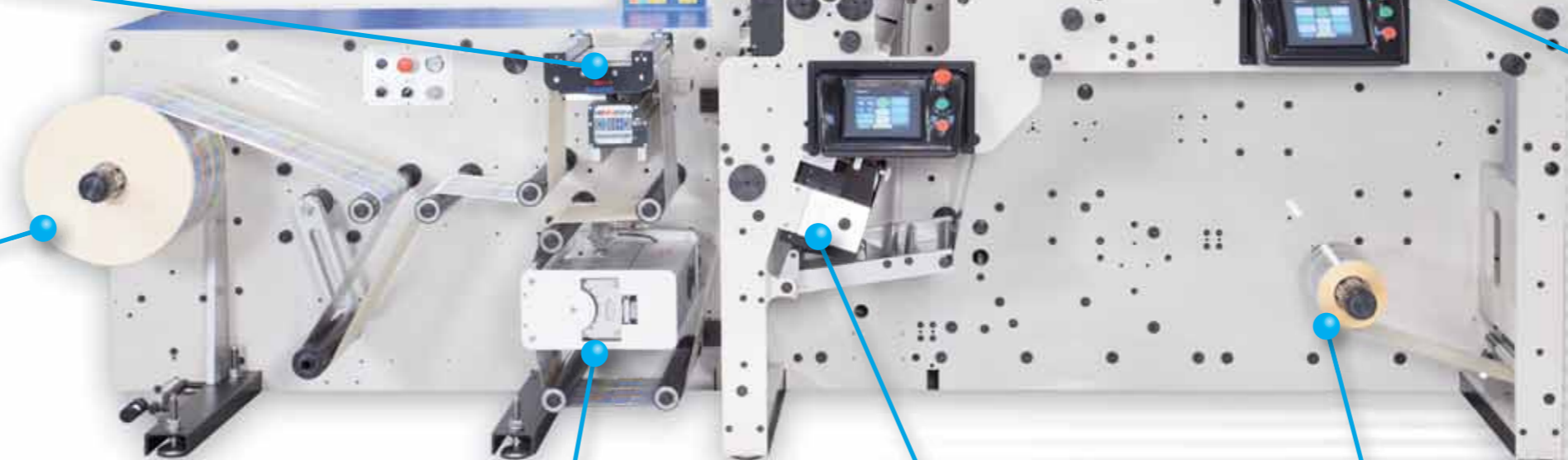
SERVO DRIVE TECHNOLOGY
The new drive system provides precise control of the web. The closed loop digital tension system monitors in feed and rewind tensions to ensure smooth running from maximum diameter to the end of the roll.



DIGITAL INK JET
For Variable Print, Focus presents an Ink Jet system in cooperation with Digital Print Inc. The system can handle high volumes of data for printing security information, bar codes, sequential numbers and variable text.



CORONA TREATER & WEB CLEANER
Focus provides the facility to add a wide range of options including single or double sided web treatment systems. Anti-static systems can also be supplied for Synthetic Substrates.



DRYING TECHNOLOGY
A choice of advanced systems are available. Infrared systems are standard combined with forced air & waste extraction. An integrated UV system is optional. All systems are adjusted through the PLC control system to adjust with press speed.



REWIND
A direct Servo Driven Rewind ensures that rolls are perfectly wound ready for further finishing operations or direct delivery to your client. 75mm Air cores are standard, and alternative cores sizes can be supplied.

REFLEX WITH LARGE CAPACITY UNWIND



R E F L E X ' S ' S P E C I F I C A T I O N S

Number of Colours	1	Rotary Slitting	Standard
Re-Register System	Optional	Max Unwind Diameter	650mm (Std) 1000mm(Optional)
Max Print Width	10"(254mm)/13"(330mm)	Max Rewind Diameter	22" (600mm)
Print Range	7-20" (178-510mm)	Max Speed	120m/min (Mechanical)
I.R Drying	Standard	Other Options	
U.V Drying	Optional	Turn Bar, Cold Foil, Lamination, Rotary Cutting/Slitting, Sheet Stacker,	
Rotary Die Cutting	1 std, 2nd Optional	Web Cleaner, Corona Treater, Video Inspection. Double Unwind,	
Rotary Sheeting	Standard	Double Rewind, Digital Ink-jet.	

Reflex with unwind, turn-bar and stacker

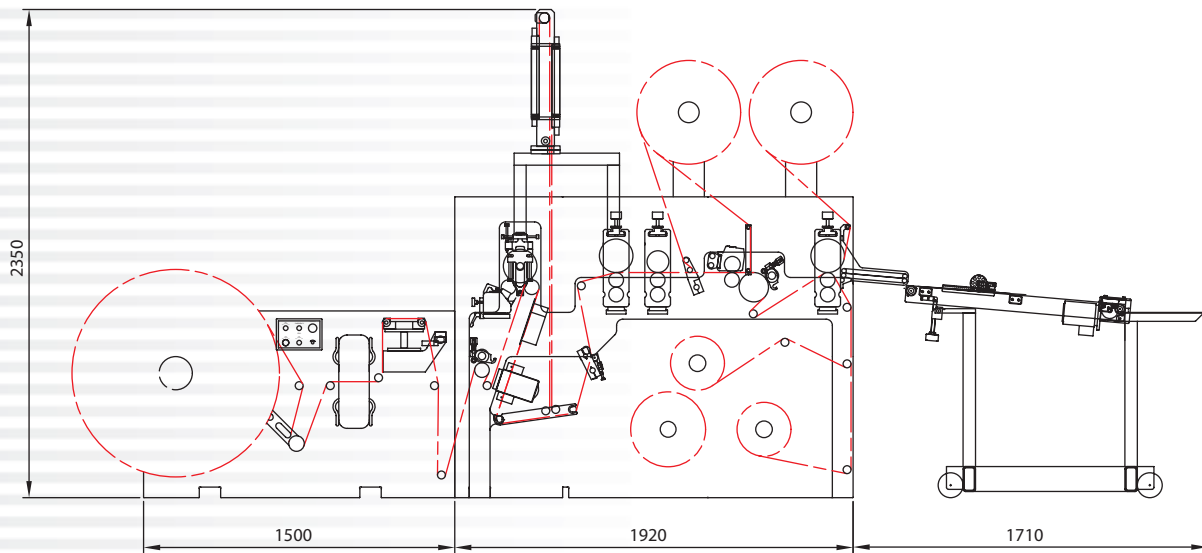

Reflex with turn-bar and stacker

